



WESTERN STAR 4900 – XD15 OFFROAD
Klein K650
6500 Gallon Water Truck



Jacksonville, TX 75766, USA
Ph: 909-460-4546 | Fax: 909-460-4545
www.kleinproducts.com





WESTERN STAR 4900 – XD15 OFFROAD
Klein K650
6500 Gallon Water Truck

THE SAFEST WAY TO GET THE WATER WHERE YOU WANT IT.

The innovative Klein patented trapezoid tank body installed on the Western Star XD15 Offroad chassis creates a truck with a low center of gravity for greater stability. This low center of gravity, combined with wide track of the XD15, enhances safety by reducing the risk of rollover. The rigid frame construction allows drivers to sense the terrain better than when in an articulated unit, further allowing them to detect and avoid rollover situations. Additionally, Western Star's extra-wide cab, along with Klein's trapezoid tank design, provides better views for optimal operator and job site safety. And the PFC™ (Precision Flow Control) baffling system allows maximum water output while maintaining complete live load movement control for even greater safety.





WESTERN STAR 4900 – XD15 OFFROAD
 Klein K650
 6500 Gallon Water Truck

FEATURES & BENEFITS: CHASSIS

PROVEN DURABILITY MEANS GREATER PRODUCTIVITY.

Western Star has been building rugged, hard-working equipment since 1967. And the result of this work is the XD Offroad package. The extreme-duty XD Offroad delivers a dependable and affordable option to the more costly rigid and articulated trucks with a selection of features to maximize uptime and profitability.



FEATURES:	BENEFITS:
REDUCED MAINTENANCE TIME	
Steel, butterfly hood	Quick fluid checks and long life
Fender and air cleaner disconnect system	Quick and easy engine access
Planetary gear sets	Manage massive loads while remaining easy to work on
Available central lube and other time saving systems	Reduced maintenance time
INCREASED UPTIME	
Large copper-brass radiator	Excellent cooling and in-field reparability
Shock-mounted radiator	Reduced downtime and repairs
Point-to-point electrical system with in-cab fuse panels	Quicker diagnosis and repair
Steel chassis wiring standoffs	Quicker circuit tracing and repair
UNMATCHED POWER	
Detroit™ engine options	Multiple models and power ratings to tailor the engine to the job while maximizing fuel efficiency



WESTERN STAR 4900 – XD15 OFFROAD
 Klein K650
 6500 Gallon Water Truck

FEATURES & BENEFITS: BODY

**AFFORDABLE TO BUY.
 AFFORDABLE TO RUN.**

Well-positioned for the job at hand, the Klein K650 unit competes head-to-head with units that are more costly with respect to operation performance and initial purchase price, and offer a number of unique benefits.



FEATURES:	BENEFITS:
IMPROVED SAFETY	
Patented trapezoid tank design	Better visibility for greater driver and job site safety
PFC™ (Precision Flow Control) baffling system	Allows maximum water output while maintaining complete live load movement control for safety
Flanged head and baffle tank construction	10 times stronger and more reliable than tanks constructed with non-flanged, butt weld systems
PRECISE APPLICATION	
Six independently cab operated adjustable spray heads	Ensure wide and very precise road coverage and maximum water usage at all times and for all road layouts
SMARTSPRAY™ hydraulic control system	Allows operators to quickly water areas in one pass while obeying safety limits or slower travel speeds
Cab operational remote spray nozzle system	Lets the operator wet down areas remotely for dust suppression and off road water placement



WESTERN STAR 4900 – XD15 OFFROAD
 Klein K650
 6500 Gallon Water Truck

FEATURES & BENEFITS: BODY

**THE BIGGER THE CHALLENGE,
 THE BETTER IT PERFORMS.**

The K650 can be equipped with the front engine PTO or rear engine PTO-driven Klein SMARTSPRAY™ system that makes your operator’s job easier and ensures years of worry-free, low maintenance performance under the most adverse conditions.



FEATURES:	BENEFITS:
GREATER PRODUCTIVITY	
Hydraulic control system to provide maximum pump operation at any desired ground speed or engine idle	Allows operators to quickly water areas in one pass while obeying safety limits in difficult conditions
INCREASED FUEL EFFICIENCY	
Allows the engine to operate at slower speeds more often	Saves on fuel and engine wear by only using power required for specific water application needs
IMPROVED SAFETY	
Better hands-free operation	Increased driver attention to avoid dangers around them



WESTERN STAR 4900 – XD15 OFFROAD
 Klein K650
 6500 Gallon Water Truck

DIMENSIONS

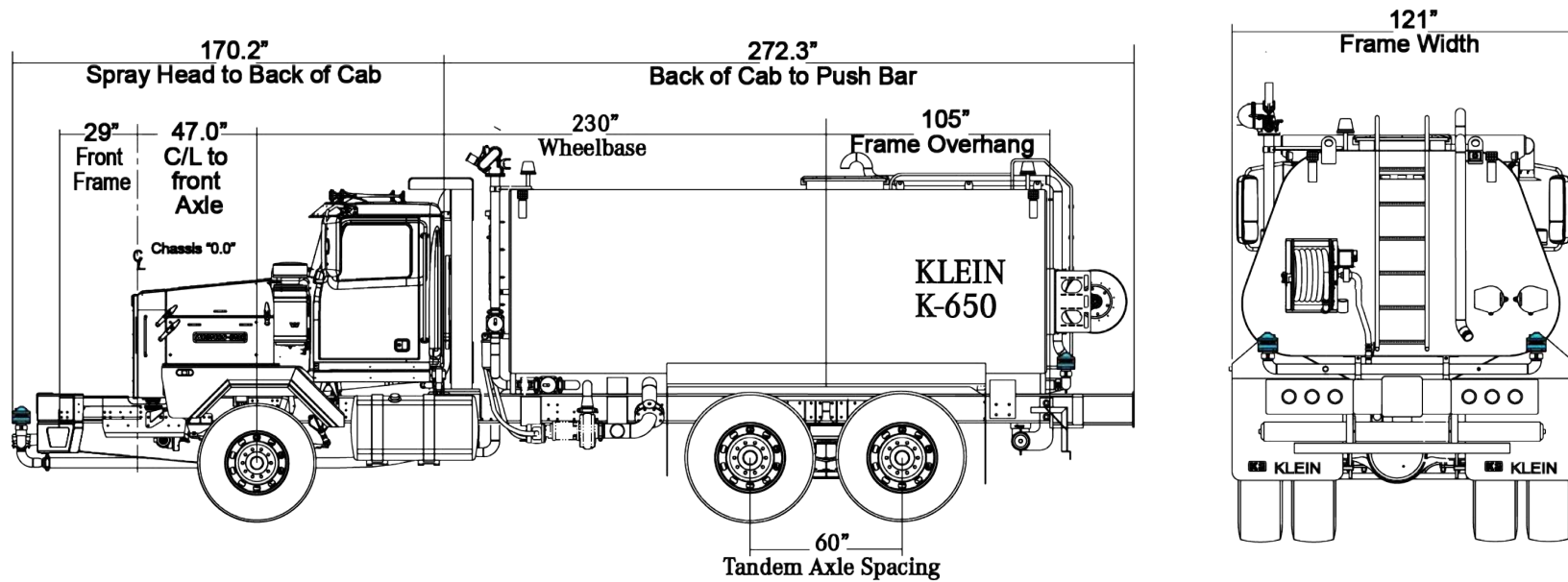



WESTERN STAR 4900 – XD15 OFFROAD
 Klein K650
 6500 Gallon Water Truck

TECH SPECS: CHASSIS

ITEM	KEY	STANDARD	OPTIONAL
A	All-steel cab with severe service reinforcement package for long service life and added driver safety	•	
B	HD air bag rear cab mounts and extreme duty top mount front cab mount, crossmember driver comfort and cab durability	•	
C	Detroit™ Series 60® Tier III engine with no EGR or DEF system requirements available for offroad only applications eliminates exhaust regen and DEF requirements	•	
	Detroit™ DD15®/DD16® EPA 10 engine with up to 600HP and 2050 torque ratings, EPA 10 units are standard with EGR or DEF systems		•
D	Simple and robust point-to-point wiring system is easy to maintain and is designed to reduce electrical issues for greater vehicle uptime	•	
E	In-cab electrical panels and weather-protected chassis and engine connections prevent corrosion and damage from outside elements	•	
F	Steel braided air and electrical lines are clamped separately in the rail with steel tie downs for maximum durability in mud and snow and easy access for service	•	
G	Dual 14-inch Donaldson outside air cleaners	•	
H	Capacity for three (3) frame rails with 6.7MM RBM load capacity		•
I	Long-life steel fuel and hydraulic tanks for more safety, equipped with extreme duty still tank supports	•	
J	Heavy-gauge aluminum fender butterfly hood with shock mounted radiator designed for long life service and safe engine access		•
K	Durable, extra-capacity copper brass radiator for durability and easy on-site field repairs	•	
L	Roof mounted AC condenser for maximum cooling and comfort in dusty conditions	•	
M	11-inch single heavy-duty steel bumper with integral removable tow pin	•	
N	Double slippered front suspension system provides maximum load capacity with smooth ride and handling in rough road conditions	•	
O	Rugged front skid pan for engine and transmission cooler protection	•	
P	Click to start seat belt ensure drivers are safe before moving		•
Q	Certified ROPS and FOPS systems available		•

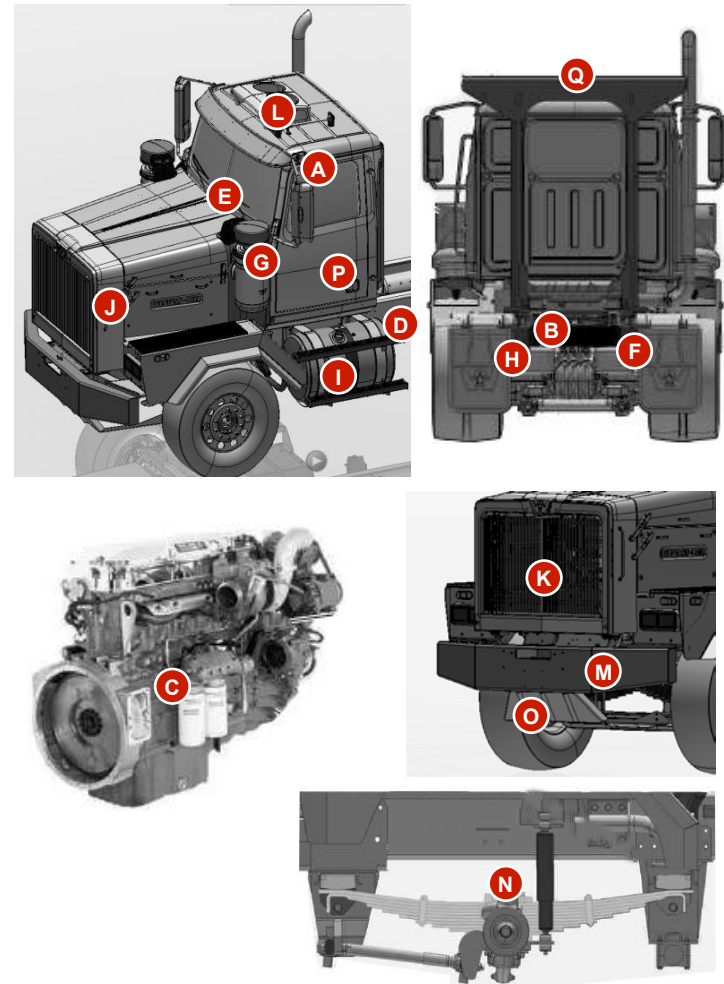



WESTERN STAR 4900 – XD15 OFFROAD
 Klein K650
 6500 Gallon Water Truck

STANDARD FEATURES AND OPTIONS

STANDARD PUMP SYSTEM FEATURES

Klein KP4H 1000 GPM hydraulically driven centrifugal pump with close coupled hydraulic motor
Drive system includes oil reservoir, return line oil fitter, high pressure oil filter and pressure relief valve
Oil lubricated pump with mechanical seal (superior to packing gland) anti-vortex cross inlet pipe with trash screen
Pressure manifold designed for easy pump maintenance
Flexible or dresser type coupling available per customer preference

STANDARD DISCHARGE SPRAY FEATURES

Rear spray bar:	Four (4) fully adjustable spray heads with individual cab controls
Front spray bar:	Two (2) fully adjustable spray heads with individual cab controls
Driver side and passenger side spray:	Klein side jet spray heads with in cab controls
Spray controls:	In cab control station console pedestal
Pressure outlet group:	Pressure manifold equipped with 1 – 1 1/2" and 1 – 3/4" quarter turn ball valves for easy shut off and control

OPTIONAL ITEMS

Suction loading with self priming reservoir and hoses and two 10' hose sections with storage tubes
Hose reel with 50' x 1 1/2" hose and nozzle
Tank mounted remote operated water cannon
Passenger side spray head with in cab control
Gravity bar or splash plate with in cab control
100% interior of tank coated with KleinFlex Elastomeric Urethane
Cold weather prep package
"KleinView" Safety operations rear view camera includes in cab display screen for improved operator safety by offering a clear view while backing





Klein Products

North America, Western Region;

Europe; Asia; Africa:

Ph: 800-646-4546

Hours: 8:00 a.m. to 5:00 p.m.

Fax: 909-460-4545

North America, Eastern Region:

Ph: 888-589-4546

Hours: 7:00 a.m. to 4:30 p.m. CST

Email: info@kleinproducts.com



Western Star Trucks

Customer Assistance Center

Ph: 866-850-STAR
(866-851-7827)