



WESTERN STAR 6900 – XD40 OFFROAD
Ground Force GF40DB
40-Ton Dump Truck



5650 E. Seltice Way | Post Falls, ID 83854, USA
Ph: 208-664-9291 | Fax: 208-664-9475
E-mail: info@gfworldwide.com | www.gfworldwide.com





**WESTERN STAR 6900 – XD40 OFFROAD
GROUND FORCE GF40DB
40-TON DUMP TRUCK**

**READY TO WORK,
DAY AFTER DAY AFTER DAY.**

The well-engineered Ground Force 40-ton dump body paired with the rugged Western Star XD Offroad chassis is a combination that goes far beyond heavy-duty. These units make moving material look easy, with planetary gear set options that are capable of hauling massive loads, yet keep the chassis open and simple to work on. Reduced scheduled maintenance time and a low cost of operation ensure that the Western Star XD Offroad chassis can deliver value while standing up to the rigors of hard work.





**WESTERN STAR 6900 – XD40 OFFROAD
GROUND FORCE GF40DB
40-TON DUMP TRUCK**

FEATURES & BENEFITS: CHASSIS

**PROVEN DURABILITY MEANS
GREATER PRODUCTIVITY.**

Western Star has been building rugged, hard-working equipment since 1967. And the result of this work is the XD Offroad package. The extreme-duty XD Offroad delivers a dependable and affordable option to the more costly rigid and articulated 40-ton haul trucks with a selection of features to maximize uptime and profitability.



FEATURES:

REDUCED MAINTENANCE TIME

- Steel, butterfly hood
- Fender and air cleaner disconnect system
- Planetary gear sets
- Available central lube and other time saving systems

INCREASED UPTIME

- Large copper-brass radiator
- Shock-mounted radiator
- Point-to-point electrical system with in-cab fuse panels
- Steel chassis wiring standoffs

UNMATCHED POWER

- Detroit™ engine options

BENEFITS:

- Quick fluid checks and long life
- Quick and easy engine access
- Manage massive loads while remaining easy to work on
- Reduced maintenance time

- Excellent cooling and in-field reparability
- Reduced downtime and repairs
- Quicker diagnosis and repair
- Quicker circuit tracing and repair

- Multiple models and power ratings to tailor the engine to the job while maximizing fuel efficiency



**WESTERN STAR 6900 – XD40 OFFROAD
GROUND FORCE GF40DB
40-TON DUMP TRUCK**

FEATURES & BENEFITS: BODY

**BUILD YOUR BOTTOM LINE
WITH EVERY LOAD.**

Ground Force has a long history of listening to customers and developing innovative cost effective solutions. Combining this passion and commitment to excellence, the new GF40DB 40-ton capacity dump delivers a number of features to help your bottom line.



FEATURES:	BENEFITS:
UNMATCHED VERSATILITY	
Forward-thinking design	Adaptable for multiple applications
IMPROVED SAFETY	
Innovative semi-elliptical body design	Keep loads centered
INCREASED LONGEVITY	
Multiple liner packages available	Provides optimal wear and prevents delamination





**WESTERN STAR 6900 – XD40 OFFROAD
GROUND FORCE GF40DB
40-TON DUMP TRUCK**

TECH SPECS: CHASSIS

ITEM	KEY	STANDARD	OPTIONAL
A	All-steel cab with Severe Duty reinforcement package for long service life and added driver safety	•	
B	Dual heavy-duty air rear cab mounts and Extreme Duty top mount front cab crossmember provides driver comfort and cab durability	•	
C	Detroit™ Series 60® Tier III engine with no EGR or DEF system requirements available for offroad only applications eliminates exhaust regen and DEF 14.7L requirements		•
	Detroit™ DD15®/DD16® GHG 17 engine with up to 600HP and 2050 (manual) or 1850 (automatic) torque ratings, standard with EGR or DEF systems	•	
D	Dual Donaldson STG Donaclone two-stage air cleaner for maximum dust filtration and long filter life (available with butterfly hood only)	•	
E	Available quadruple-channel frame rails with 6.7M RBM load capacity		
F	Long-life steel fuel hydraulic tanks equipped with Extreme Duty heavy steel tank supports	•	
G	Steel fender butterfly hood with shock mounted radiator designed for long life and safe engine access	•	
H	Durable, extra-capacity Glacier Core copper brass radiator for durability and easy on-site field repairs	•	
I	Roof-mounted AC condenser for maximum cooling and comfort in dusty conditions	•	
J	22-inch double Extreme Duty steel bumper with radiator protector and integral removable tow pin	•	

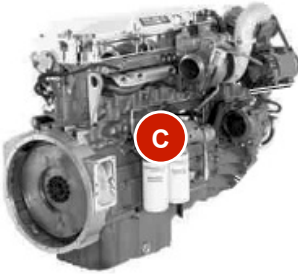
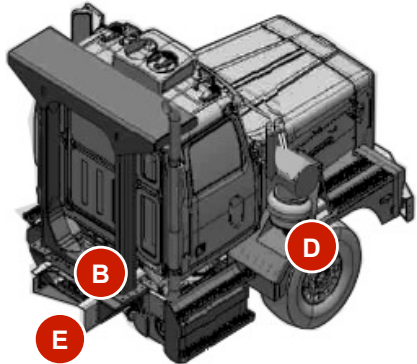
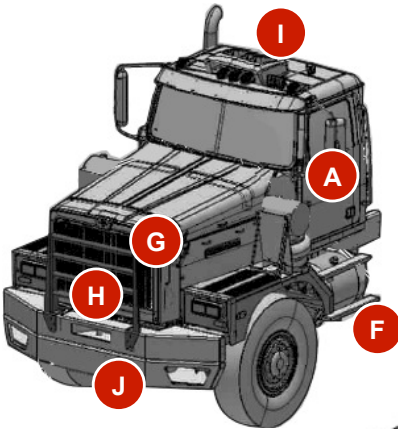



**WESTERN STAR 6900 – XD40 OFFROAD
GROUND FORCE GF40DB
40-TON DUMP TRUCK**

TECH SPECS: CHASSIS

ITEM	KEY	STANDARD	OPTIONAL
A	AxleTech SPRC1927 110,000 lb planetary tandem rear axle	•	
B	Chalmers 865 11,000 lb rear suspension	•	
	Hendrickson R1000 110,000 lb rear suspension		•
C	28,000 lb double slippered rear suspension. Torque rod controlled axle offering maximum load capacity and long spring life in rough road conditions		•
D	AxleTech 28,000 lb planetary front drive axle with 6x6 configuration		•
	SISU FSND12G 28,000 lb single front steer axle	•	
E	Quadruple-channel frame rails with 6.7M RBM load capacity		•

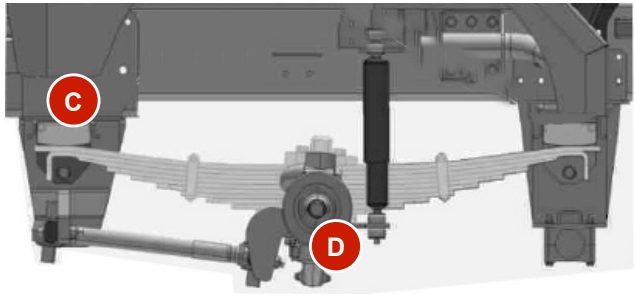
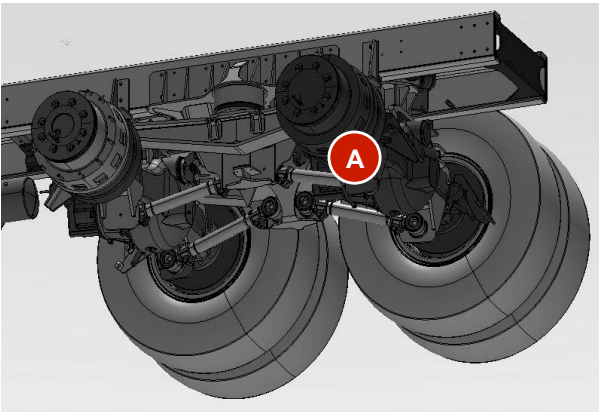
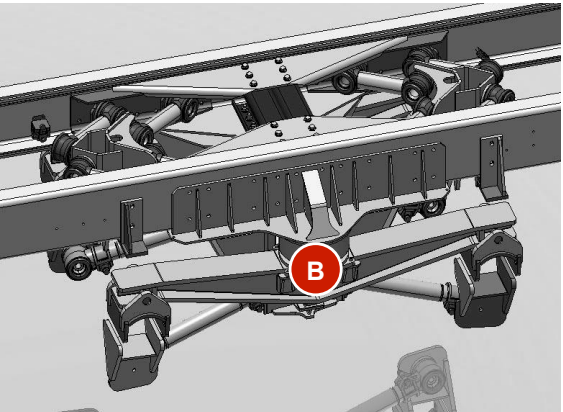
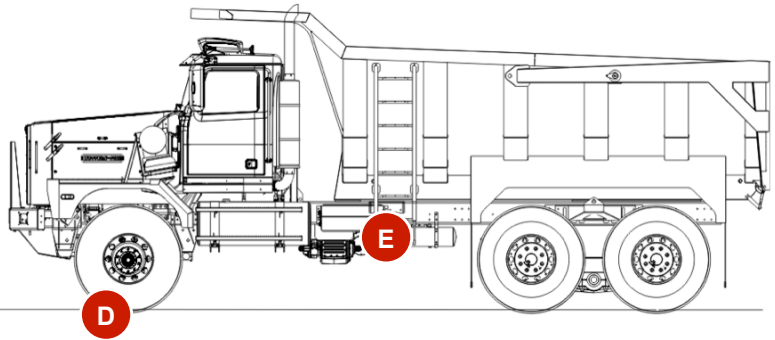



**WESTERN STAR 6900 – XD40 OFFROAD
GROUND FORCE GF40DB
40-TON DUMP TRUCK**

TECH SPECS: BODY

SPECIFICATIONS	IMPERIAL	METRIC	NOTES
Max Capacity Struck	29.25 lcy	789.75 lcf	Based on material density of 2400 lb/lcy
Max Capacity Heaped	34.53 lcy	932.31 lcf	Based on material density of 2400 lb/lcy
Empty Weight	12,500 lbs	5670 kg	
Box Length	295 inches	750 cm	Includes cab guard
Box Width	134 inches	340 cm	Fender to fender
Body Height	99 inches	251 cm	Above truck frame to top of cab guard
Box Interior Depth	64 inches (at front)	162 cm	56 inches / 142 cm (at rear)
Box Floor	1/4-inch HARDOX 450		
Bolster and Cab Guard	WELDOX 700		
Paint	Standard White – Custom colors available		

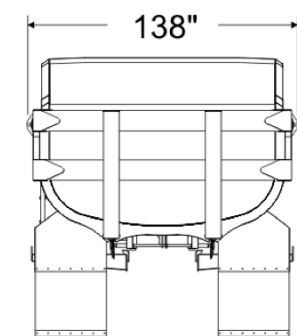
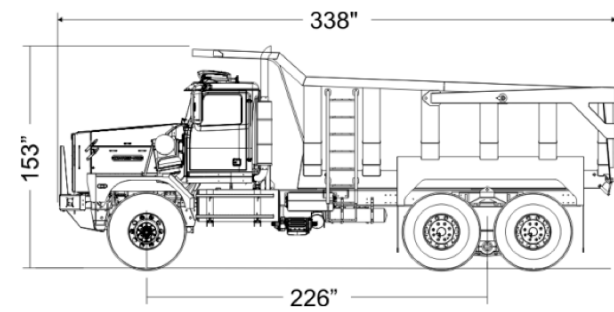
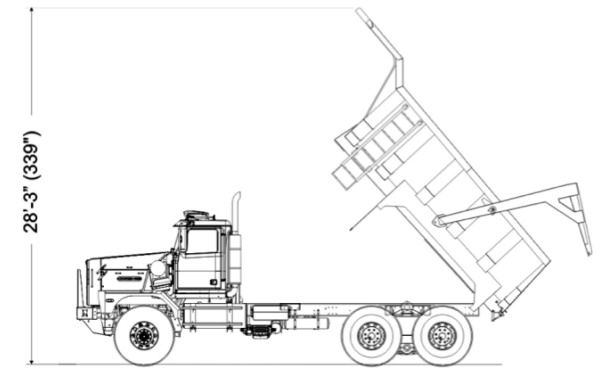

SPECIFICATIONS	IMPERIAL	METRIC	NOTES
Live Gate	•		Heavy-duty hinge set
Hi-Lift Tailgate		•	
Rock Knockers		•	Available on request
Backup Camera		•	Available on request
Box Liner		•	3/8-inch HARDOX 450 steel liner



5650 E. Seltice Way
Post Falls, ID 83854 USA

Ph: 208-664-9291
Fax: 208-664-9475
E-mail: info@gfworldwide.com

www.gfworldwide.com

Western Star Trucks
Customer Assistance Center

Ph: 866-850-STAR
(866-851-7827)